



# Infinity FA2i Air Winches

2,000 kg (4,400 lb)

**Adjustable drum guard**—optional but recommended for all applications (standard with -CE option)

**Minimum 18:1** drum diameter to wire rope diameter

**Lifting lugs** designed for lifting weight of winch plus full drum of wire rope

**Lift-to-Shift variable speed lever** provides precise control and built-in safety

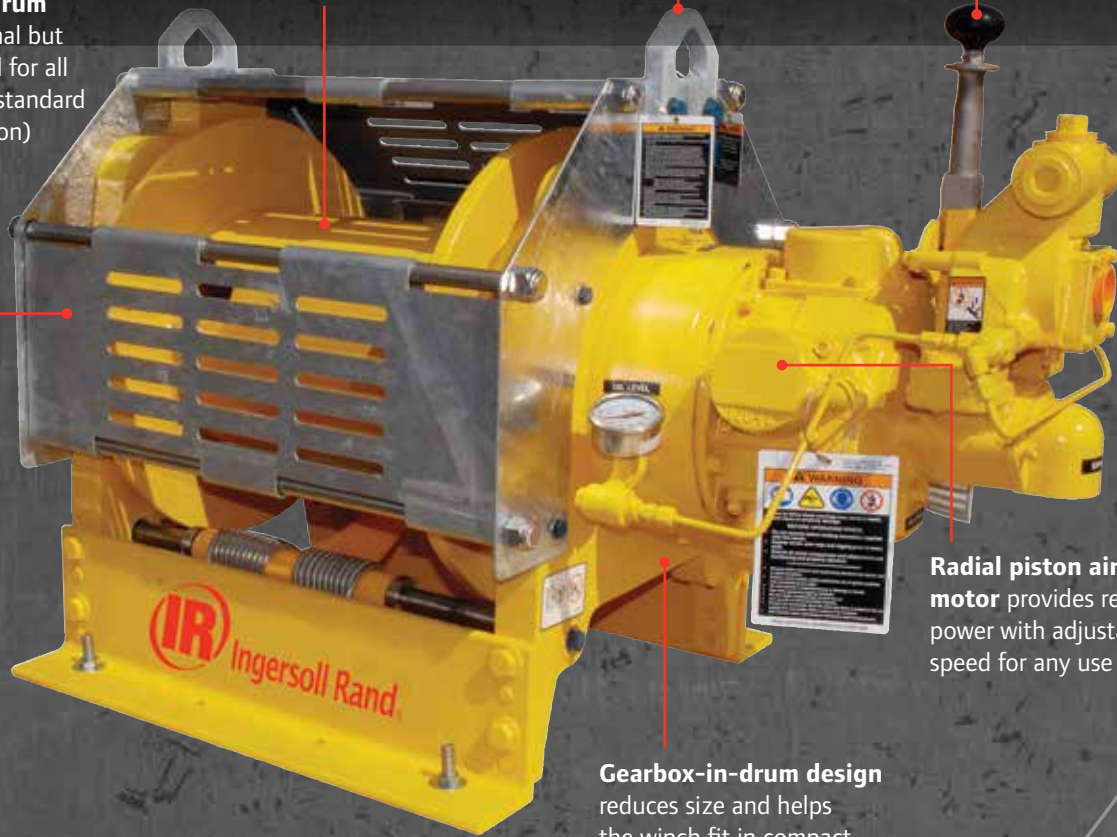

**Radial piston air motor** provides reliable power with adjustable speed for any use

**Gearbox-in-drum design** reduces size and helps the winch fit in compact applications

Ideal for:



Onshore



Offshore



Marine



# Infinity FA2i Air Winches

2,000 kg (4,400 lb)

Ingersoll Rand Infinity FA2i air winches set the standard in winch technology with premium features and options. Designed to handle 2 tons or less the FA2i winch packs a powerful radial piston air motor into a compact size. Count on the Infinity FA2i winch when you need reliable power in a space saving design.

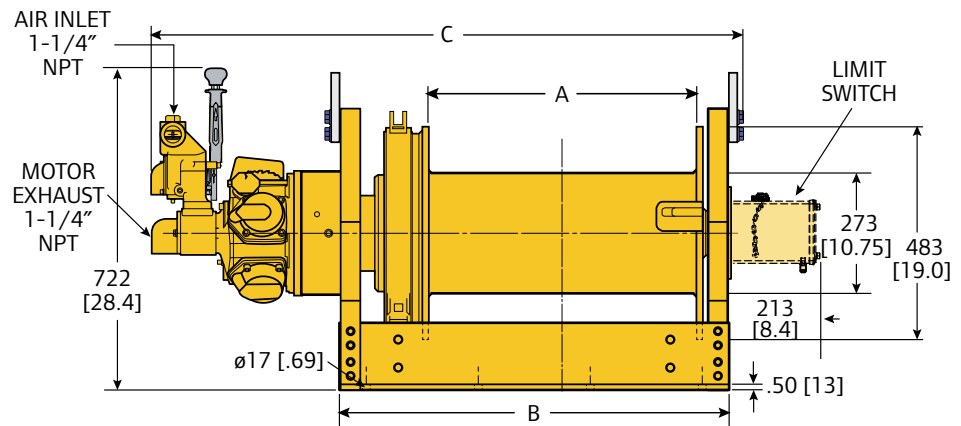

### Bolt Pattern

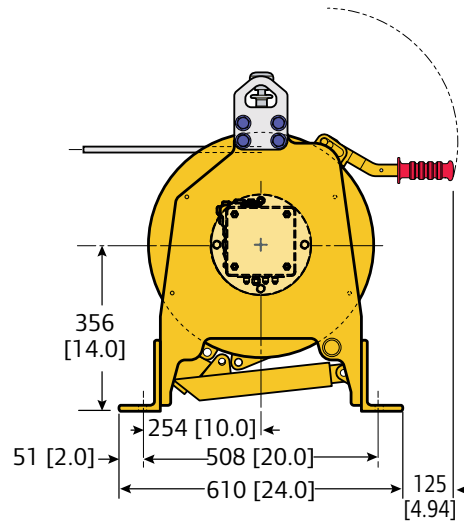
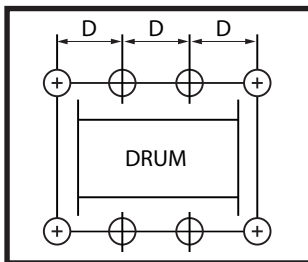

MX, MK and AK Option

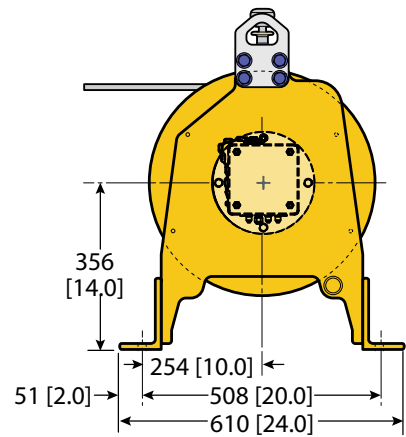

XK Option

Dimensions shown are mm. Dimensions in Brackets [ ] are inches. Dimensions are subject to change. Contact factory for certified drawings.

Model	A		B		C		# of Bolt Holes	Bolt Pattern D	
	MX, MK, XK, AK mm (in)	MX, MK, AK mm (in)	XK mm (in)	MX mm (in)	XK mm (in)	MK, AK mm (in)		MX, MK, AK mm (in)	XK mm (in)
FA2i-12**1	305 (12.0)	579 (22.8)	511 (20.11)	968 (38.1)	945 (37.2)	1,036 (40.8)	6	229 (9.0)	191 (7.5)
FA2i-16**1	406 (16.0)	681 (26.8)	612 (24.11)	1,069 (42.1)	1,046 (41.2)	1,138 (44.8)	8	191 (7.5)	159 (6.3)
FA2i-20**1	508 (20.0)	782 (30.8)	714 (28.11)	1,171 (46.1)	1,148 (45.2)	1,240 (48.8)	8	229 (9.0)	197 (7.8)
FA2i-24**1	610 (24.0)	884 (34.8)	816 (32.11)	1,273 (50.1)	1,250 (49.2)	1,341 (52.8)	8	254 (10.0)	229 (9.0)

\*\* Indicated brake configuration. **MX**: Manual drum, no auto disc; **XK**: No manual drum, auto disc; **MK**: Manual drum, auto disc; **AK**: Auto drum, auto disc. Dimensions subject to change. Contact factory for certified prints. **NOTE**: Limit switches standard on -CE versions only.



Grooved Drum



Press Roller



Optional drum guards

**General Performance. Performance based on a 5:1 design factor**

Model	Line Pull Capacity			Line Speed		
	First Layer kg (lb)	Mid Drum kg (lb)	Top Layer kg (lb)	First Layer m/min (fpm)	Mid Drum m/min (fpm)	Top Layer m/min (fpm)
FA2i-12**1	2,980 (6,600)	2,490 (5,500)	2,000 (4,400)	10 (34)	13 (42)	16 (51)
FA2i-16**1	2,980 (6,600)	2,490 (5,500)	2,000 (4,400)	10 (34)	13 (42)	16 (51)
FA2i-20**1	2,980 (6,600)	2,490 (5,500)	2,000 (4,400)	10 (34)	13 (42)	16 (51)
FA2i-24**1	2,980 (6,600)	2,490 (5,500)	2,000 (4,400)	10 (34)	13 (42)	16 (51)

**General Characteristics. Performance at 6.3 bar (90 psi) air inlet pressure with the motor running**

Model	Motor	Lifting Speed at Top Layer	Air Consumption with Rated Load	Air Volume Needed to Move Rated Load at Top Layer	Stall	Sound Level as per EN 14492-1	Net Weight
	kW (hp)	m/min (fpm)	m <sup>3</sup> /min (ft <sup>3</sup> /min)	3 m (10 ft)	kg (lb)	dB(A)	kg (lb)
FA2i-12**1	7 (9)	16 (51)	8 (280)	1.5 (54.9)	4,154 (9,139)	87	386 (850)
FA2i-16**1	7 (9)	16 (51)	8 (280)	1.5 (54.9)	4,154 (9,139)	87	386 (850)
FA2i-20**1	7 (9)	16 (51)	8 (280)	1.5 (54.9)	4,154 (9,139)	87	386 (850)
FA2i-24**1	7 (9)	16 (51)	8 (280)	1.5 (54.9)	4,154 (9,139)	87	386 (850)

**Drum capacity**

Model	Minimum Rope Breaking Force <sup>(1)</sup> kN (lbs)	Recommend- ed Rope Diameter mm (in)	Drum Capacity per Layer <sup>(2)</sup> m (ft)								Max. Rope Storage Capacity <sup>(3)</sup> m (ft)
			Layer 1	Layer 2	Layer 3	Layer 4	Layer 5	Layer 6	Layer 7	Layer 8	
FA2i-12**1	98 (22,000)	13 (1/2)	20 (67)	42 (141)	65 (220)	91 (305)	118 (395)	147 (492)	177 (594)	210 (702)	210 (702)
FA2i-16**1	98 (22,000)	13 (1/2)	27 (91)	56 (190)	88 (297)	122 (411)	159 (533)	198 (663)	239 (800)	283 (946)	283 (946)
FA2i-20**1	98 (22,000)	13 (1/2)	34 (114)	71 (239)	111 (373)	154 (517)	200 (671)	249 (834)	301 (1,007)	356 (1,190)	356 (1,190)
FA2i-24**1	98 (22,000)	13 (1/2)	41 (138)	86 (288)	134 (450)	186 (623)	241 (808)	300 (1,005)	363 (1,214)	429 (1,434)	429 (1,434)

<sup>(1)</sup> Recommended minimum breaking force of wire rope based on top layer line pull rating.

<sup>(2)</sup> Drum Capacity is based on tightly wound wire rope. Recommended drum working capacity is 80% of values shown.

<sup>(3)</sup> Max storage capacity is tightly wound with no freeboard.

## How to Order

	<b>FA</b>	<b>2i</b>	<b>- 24</b>	<b>X</b>	<b>K</b>	<b>220</b>	<b>- 14GP1</b>	
<b>Series</b>	<b>Capacity</b>	<b>Drum Length (inches)</b>	<b>Drum Brake</b>	<b>Disc Brake</b>	<b>Control</b>	<b>Options</b>		
<b>FA</b> Air powered	<b>2i</b> 4,400 lb	<b>12</b> <b>16</b> <b>20</b> <b>24</b> std	<b>X</b> No drum brake <b>M</b> Manual drum brake <b>A</b> Auto drum brake	<b>X</b> No auto disc brake <b>K</b> Disc brake	<b>1</b> Std. throttle lever <b>2xx</b> Remote full flow lever throttle <b>3xx</b> Remote pilot pendant throttle <b>4xx</b> Remote pilot lever throttle <b>5xx</b> Electric over air control  <b>xx</b> Specify hose/elec. cord length in ft	<b>14</b> Drum grooving (specify rope size in sixteenths; e.g., 14 = 14/16" or 7/8") <b>B</b> Extended warranty <b>C1M3</b> -20° C ABS design temperature <b>C2M3</b> -20° C DNV design temperature <b>D</b> Drum divider flange & additional cable anchor <b>E</b> Construction cage <b>G</b> Drum guard <b>J<sup>(1)</sup></b> Air Line Accessories <b>L</b> Drum Locking Pin <b>M1<sup>(2)</sup></b> Material Traceability per DIN 50049/EN10204 Para 2.2 "Typicals" <b>M2<sup>(2)</sup></b> Material Traceability per DIN 50049/EN10204 Para 3.1b actuals per product as purchased <b>M3<sup>(2)</sup></b> Material Traceability per DIN 50049/EN10204 Para 3.1b actuals per product as delivered in final condition <b>N4</b> Manufactured under ABS survey <b>N5</b> Manufactured under DNV survey <b>P</b> Marine 812 finish paint <b>P1</b> Marine 812-X paint system <b>P2</b> Marine 812-X paint system - isocyanate free <b>Q</b> Adjustable Accu-Spool™ <b>S</b> Rotary limit switch (upper and lower) <b>U</b> Underwound wire rope takeoff <b>V</b> Press Roller <b>W1</b> ABS witness test <b>W2</b> DNV witness test <b>W3</b> LRS witness test <b>W4</b> Client witness of load test <b>Y</b> Overload protector with E-Stop provided on lever throttle  <b>-CE</b> <b>Compliance with the European Machinery Directive and EN14492-1 for power driven winches</b>		

**NOTE:**

- <sup>(1)</sup> Add 1 for filter, 2 for lubricator, 3 for regulator (e.g. J12). For protection during shipment and due to the wide range of installation variables, the airline accessories are shipped loose for client installation.
- <sup>(2)</sup> **M1** – Material traceability certificates according to EN 10204 (Ex DIN 50049) 2.2 on load bearing parts. This conformity document affirms (by the manufacturer) that parts are in compliance with the requirements of the order based on non-specific inspection and testing (i.e., results are typical material properties for these parts).
- M2** – Material traceability certificates according to EN 10204 (Ex DIN 50049) 3.1b on load bearing parts. These documents affirm (by a department independent of the manufacturing department) that the actual parts used in the product are in compliance with the order based on specific inspection and testing (i.e., results are actual material properties for those parts).
- M3** – Material traceability certificates according to EN 10204 (Ex DIN 50049) 3.1b on load bearing parts. These documents affirm (by a department independent of the manufacturing department) that the actual parts used in the product are in compliance with the order based on specific inspection and testing (i.e., results are actual material properties for those parts in a finished, as delivered condition).

Ingersoll Rand strongly recommends using Drum Guards with all winches to prevent inadvertent contact with winch moving parts.

## Special Orders



Ingersoll Rand can provide customized solutions for your application. Whether you need to move specialized or high capacity loads or have custom control requirements, we can build the right solution for you. Ingersoll Rand's global account management team, dedicated project managers and engineering teams are focused exclusively on high capacity hoists and winches. From evaluation to installation and beyond, contact us to build your custom solution today.

- Design for custom capacities
- Custom control systems
- Custom product modifications
- Witness testing and complete certification to most global standards
- Full engineering capabilities including data packages and CAD drawings
- Global Account Management and dedicated project management teams
- Onsite services available including presale evaluation, installation and maintenance



For More Information [www.ingersollrandproducts.com/lifting](http://www.ingersollrandproducts.com/lifting) [lifting@irco.com](mailto:lifting@irco.com)

Ingersoll Rand, IR, the IR logo and Impactool are trademarks of Ingersoll Rand, its subsidiaries and/or affiliates. All other trademarks are the property of their respective owners. Nothing contained on these pages is intended to extend any warranty or representation, expressed or implied, regarding the product described herein. Any such warranties or other terms and conditions of sale of products shall be in accordance with Ingersoll Rand's standard terms and conditions of sale for such products, which are available upon request. Product improvement is a continuing goal at Ingersoll Rand. Designs and specifications are subject to change without notice or obligation. Unless otherwise noted this equipment is not designed for transporting people or lifting loads over people. It is the user's responsibility to determine the suitability of this product for any particular use and to check compliance with applicable regulations. Before installation, see maintenance and operations manual for additional warnings and precautions.